

Hall Effect Zero Speed Sensor

F16S40

GREEN LINE
INDUSTRIAL SPEED SENSORS

Product ID

Type #	Product #	Drawing #
F16S40	385Z-05586	114.463 Rev.1

General

Function	The F16S40 series Hall effect speed sensors are suitable, in conjunction with a ferrous pole wheel, for generating square wave signals proportional to rotary speeds. They exhibit a static function, whereby pulse generation down to 0 Hz is guaranteed. The sensor function is independent of rotational mounting angle.
----------	---

Technical data

Supply voltage	8...25 VDC
Current consumption	Max. 12 mA (without load)
Signal output	Square wave signal from NPN output transistor with internal 2.7 kOhm pull-up resistor, DC-coupled to supply (negative pole = reference Voltage). Sink current: max. 25 mA Output voltage: $U_{high} \sim$ supply voltage $U_{low} < 0.5$ V at $I = 25$ mA
Frequency range	0 Hz...15 kHz
Housing	M16x1.5, tightening torque: max. 35 Nm
Connection	Cable with open leads: 3-wire, 3 x 0.34 mm ² (AWG22), stranded wires, elastomer isolation, green casing, fire retardant, low smoke, RoHS conform and halogen free, max. outer $\varnothing = 4.8$ mm, min. bending radius = 25 mm (static) and 50 mm (dynamic), cable length according to dimensional drawing
Protection	Sensor head: IP68 Cable outlet: IP67
Insulation	Housing and electronics galvanically isolated (Test: 500 V, 50 Hz for 1 minute)
Pole wheel	Prerequisite: Toothed wheel of a ferrous material (e.g. Steel 1.0036). Optimal performance with Involute gear Tooth width > 10 mm Side offset < 0.2 mm Eccentricity < 0.2 mm
Air gap between sensor and pole wheel	Module 1.0 (DP 25.4): 0.3...0.5 mm Module 2.0 (DP 12.7): 0.3...1.5 mm
Electromagnetic compatibility (EMC)	Please contact Jaquet for further details.
Vibration & shock immunity	Jaquet Greenline sensors are approved for rough environments. Please contact Jaquet for further details.
Operating temperature	-40°C...125°C

Further Information

Safety	All mechanical installations must be carried out by an expert. General safety requirements have to be met.
Installation	<p>The sensor has to be aligned to the pole wheel according to the sensor drawing independent of its rotational orientation. Deviations in positioning may affect the performance and decrease the noise immunity of the sensor. During installation, the smallest possible pole wheel to sensor gap should be set. The gap should however be set to prevent the face of the sensor ever touching the pole wheel. Within the air gap specified the amplitude of the output signal is not influenced by the air gap.</p> <p>A sensor should be mounted with the middle of the face side over the middle of the pole wheel. Dependent upon the wheel width, a certain degree of axial movement is permissible. However, the middle of the sensor must be at minimum in a distance of 3 mm from the edge of the pole wheel under all operating conditions.</p> <p>A solid and vibration free mounting of the sensor is important. Eventual sensor vibration relative to the pole wheel can induce additional output pulses.</p> <p>The sensors are insensitive to oil, grease etc. and can be installed in arduous conditions.</p>
Maintenance	Product cannot be repaired.
Transport	Product must be handled with care to prevent damage of the front face.
Storage	Product must be stored in dry conditions. The storage temperature corresponds to the operation temperature.
Disposal	Product must be disposed of properly, it must not be disposed as domestic waste.

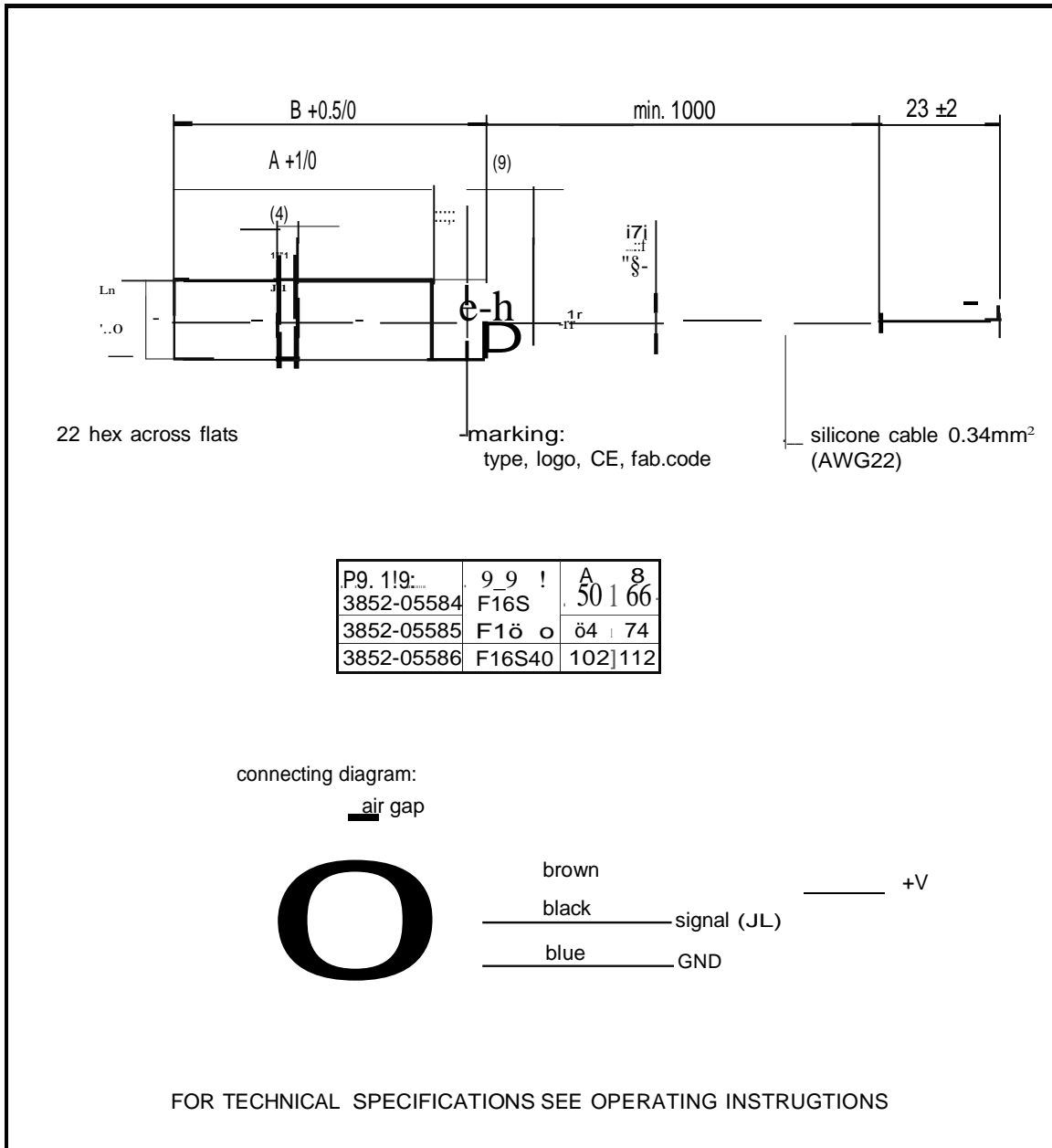

dimensions in mm			
part no.	material	remarks	üpticu tiün
-	-	-/-	nominal size range
-	-	-/-	allowed tolerance
-	-	-/-	replcement for
1	6280	10.04.07/ebi	first angle projection
rev.	ecn.	dnte/sig ature	change description
<p>JAG.UJET TECHNOLOGY GROUP</p> <p>Thannerstrusse 15 CH-4009 Basel www.juquet.com</p>			<p>part name</p> <p>speed sensor Greenline F16S</p>
<p>scale 1:1</p>		<p>approved Z7 .o(.o)</p>	<p>drawing no. 114.463</p>
<p>formal A4</p>		<p>rev. 1</p>	<p>file nme 114463.dft</p>